

OPERATION MANUAL

Version 4.3U

10 Mar 2026

Product Warranty & Limitation of Liability

The product warranty is in accordance with the following regulations:

- The manufacturer should take responsibility for below specific elements:
 1. In domestic use (as calculated from the date of invoice)
- Invoice within one month should accept replacement and repair.
- Invoice within twelve months should accept repair.
 2. Goods exported overseas (excluding Thailand) and invoice within fifteen months, the local seller is responsible for repair.
- All the distributors, agency or production place of Temp Control in whole Thailand can provide after-sales service for Temp Control product, their conditions of service as follows:
 2. We provide inspection service on the local selling place (including troubleshooting).
 3. All services comply with the related after-sale service terms and conditions stated on the agency agreement between Siam Water Flame and distributors.
 4. Buyers can pay to any Temp Control agent if need any after-sales services (whether or not the warranty).
- The product's warranty period is one year from the date of invoice. The product shall be free of defects in materials or workmanship and will conform to technical specification.
- Siam Water Flame will not be responsible for any labor costs or expenses associated with repair and replacement of defective.
- In the case of the following causes of failure, even in the warranty period is also a paid repair:
 3. Incorrect operation (depending on the use of manual), or misuse, alteration, neglect, improper, abuse, accident, or unauthorized maintenance or repair.
 4. The problems caused by using the control beyond its standard specifications requirement.
 5. Damage caused by drop down or improper handling.
 6. Controller components aged or failure caused by improper environment.
 7. Due to an earthquake, fire, wind and water disasters, lightning strikes, abnormal voltage, electrical power surge, interruption of electricity, electrical power surge or other natural disasters and disasters, accompanied by the damage caused.
 8. The damage during transport (Note: The mode of transport designated by the customer, the company's help on behalf of the procedures for handling the transfer of goods).
 9. When the manufacture's brand, trademark, serial number, nameplate and other damage or cannot be recognized.
 10. If the buyer has not paid full money according to purchase agreement.
 11. The installation, wiring, operation, maintenance or other use of objective reality cannot be described to the company's service office.
- Concerning replacement and repair services, goods shall be returned Temp Control to company, after confirmed the attribution of responsibility then they are allowed to be returned or repaired.

The user should be aware and alert that something may fail beyond our control exists. Since farm condition and livestock environment may cause controller damage, the user should provide adequate back up and alarm system. These are to operate critical system even in case of Temp Controller system failure. Neglecting to provide such a backup will be regarded as the user's willingness to accept the risk of loss, injury and financial damage. In no event will Siam Water Flame be liable to user or any third party for any direct, indirect, special, consequential or incidental damages, including but not limited to any damage or injury to business earnings, lost profits or goodwill, personal injury, costs of delay, any failure of delivery, costs of lost or damaged data or documentation, lost or damaged products or goods, lost sales, lost orders, lost income. Except of the above express warranty, Siam Water Flame makes no other warranties, express or implied, relating to the products. Siam Water Flame disclaims and excludes the implied warranties of merchantability and fitness for a particular purpose. No person is authorized to make any other warranty or representation concerning the performance of the products other than as provided by Siam Water Flame.

Technician Data

Circuit system	Electricity pressure	~220 (+/-10%)	VAC
	Frequency	50~60	Hz
	Electric power	18	VA
Fireproofing rate for relay		250VAC, 3A	
Temperature for using		-20 – 60	°C
Measurement range temperature		-10.0 – 70.0	°C
	Accurate value	0.1	°C
	Deviation value	+/-1	%
Measurement range Humidity		0.0 – 99.9	%RH
	Accurate value	0.1	%
	Deviation value	+/-5	%

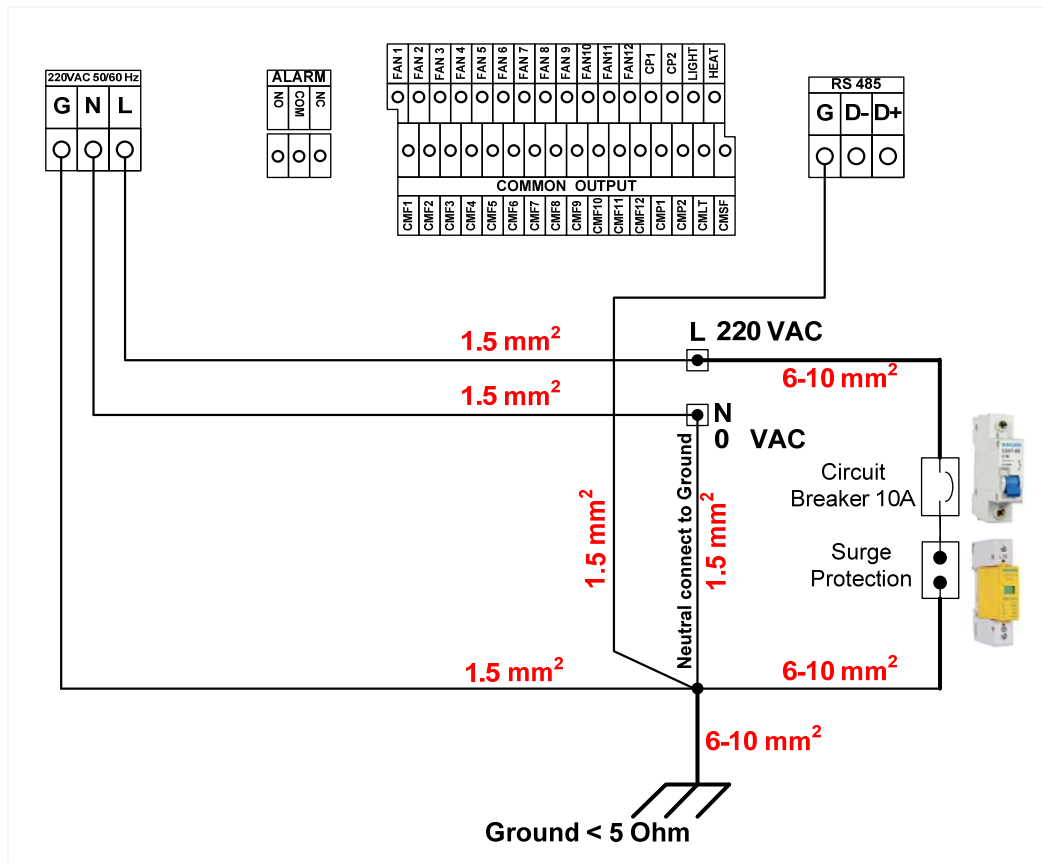

INSTALLATION

1. Connect the Temp R-tron to the wall in a dry place approximately 1 meter away from the electrical cabinet.
2. Connect a 220VAC cable to the L, N connector. This is the unit power input.
3. The Temp R-tron has not breaker (fuse) inside for this relay output and it must be installed externally.
4. Connect a protective conductor (P.E.) to the G connector. The resistance of cable must be not over than 5 ohms. We suggest that, use an independent ground cable which is not shared with the one for electricity box.

Analog Input Connections

1. Temperature sensors

T1 is used for indoor temperature sensor. Use a two wire cable.

Connect Brown wire to T1 and White/Black wire to the 0 V.

T2 is used for indoor temperature sensor. Use a two wire cable.

Connect Brown wire to T2 and White/Black wire to the 0 V.

T3 is used for outdoor temperature sensor. Use a two wire cable.

Connect Brown wire to T3 and White/Black wire to the 0 V.

T4 is used for indoor temperature sensor. Use a two wire cable.

Connect Brown wire to T4 and White/Black wire to the 0 V.

2. Humidity sensor

HUM is used for indoor humidity sensor. Use a three wire cable.

Connect Brown wire to 12V, White wire to HUM and Green wire to the 0 V.

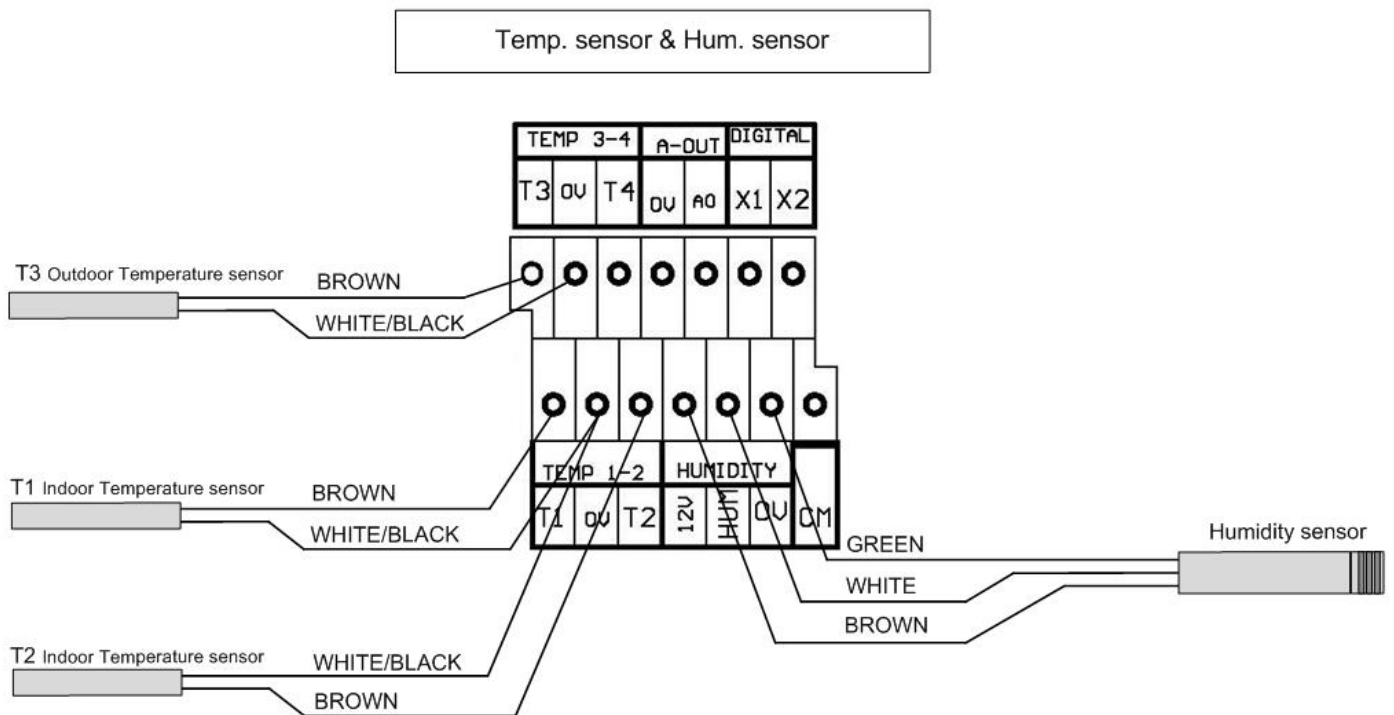

Digital Input Connection

Input 1 is used for the water meter dry contact signal. Use a two wire cable.

Connect one wire to X1 terminal and the seconds wire to CM1 terminal.

The signal from the water meter should be wired in such a way that when the water meter sends a pulse (1 pulse per 10 Liters), the dry contact will be in a normally closed state (shorted).

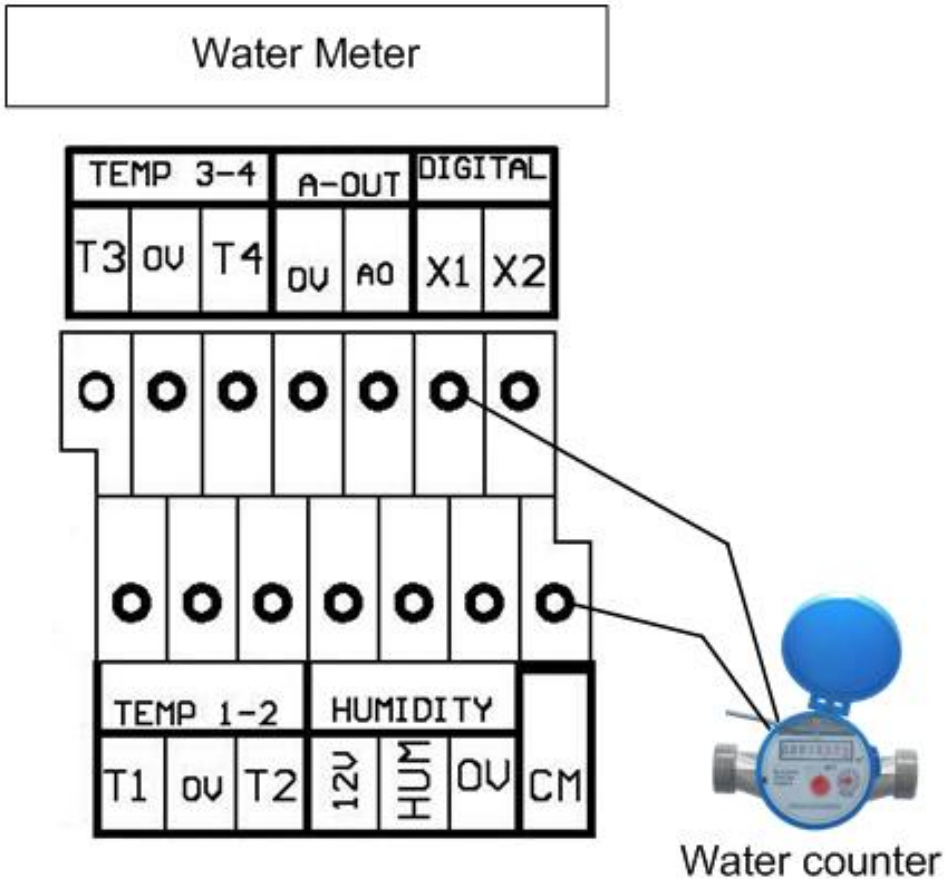

Relay Connections

Connect the relay outputs to the various systems. All outputs are dry contacts, maximum 4 A/220V

Relay list

Terminal	Output
FAN 1, CMF 1	Fan group 1
FAN 2, CMF 2	Fan group 2
FAN 3, CMF 3	Fan group 3
FAN 4, CMF 4	Fan group 4
FAN 5, CMF 5	Fan group 5
FAN 6, CMF 6	Fan group 6
FAN 7, CMF 7	Fan group 7
FAN 8, CMF 8	Fan group 8
FAN 9, CMF 9	Fan group 9
FAN 10, CMF 10	Fan group 10
FAN 11, CMF 11	Fan group 11
FAN 12, CMF 12	Fan group 12
CP 1, CMP 1	Cooling system
CP 2, CMP 2	Cooling pump 2/ Heater / Feeding
LIGHT, CMLT	Lighting system
S-FAN , CMSF	Side Fan/ Heater
NO / COM / NC	Alarm

Connect a 220VAC cable to the 220V IN connector near the ALARM connector. This is the unit power input.

Note that there is no breaker (fuse) inside the Temp R-tron for this relay output, and it must be installed externally.

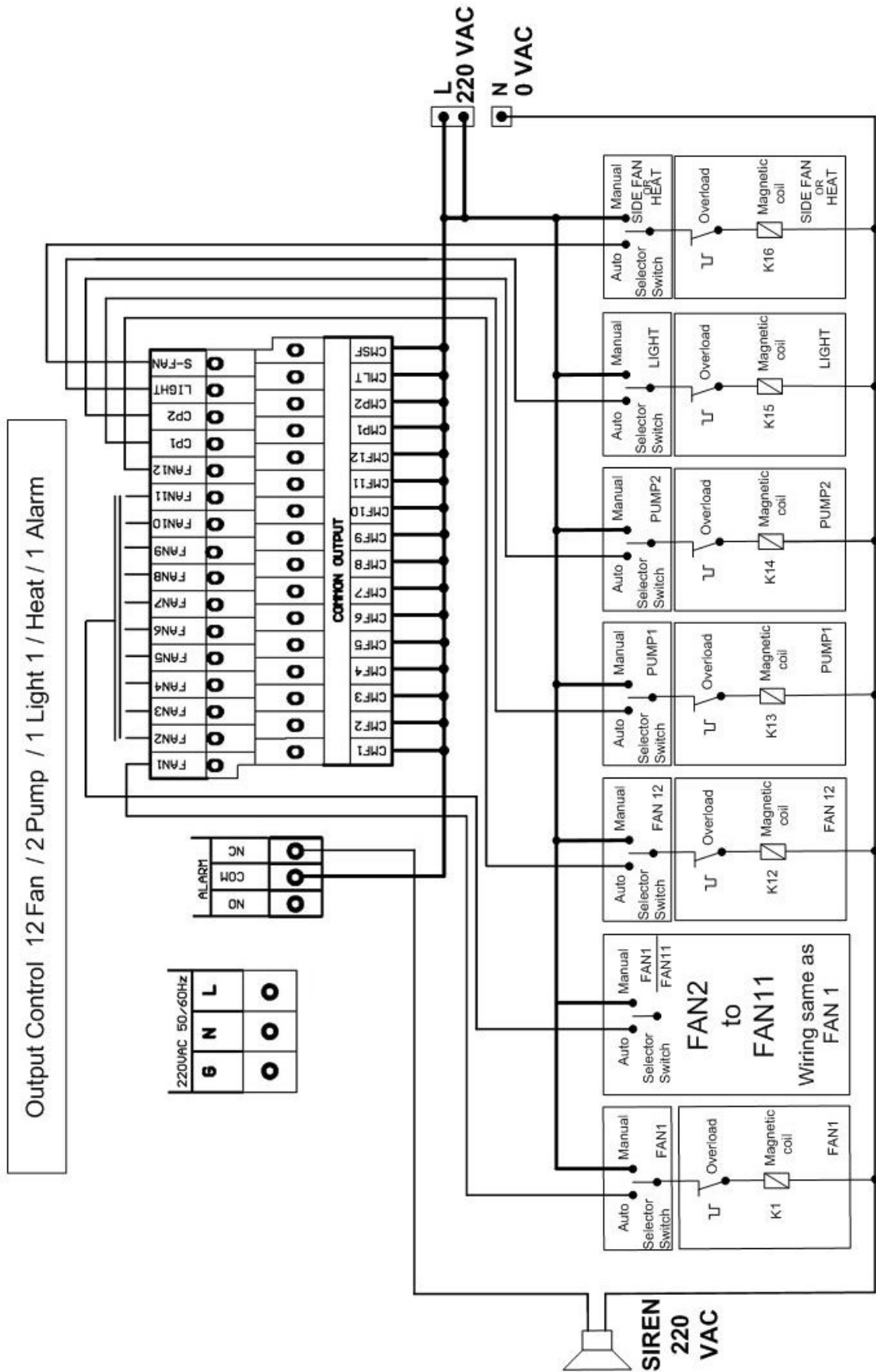

OPERATION

The Temp R-tron will display the average temperature of the connected temperature sensors. It is possible to display each sensor separately.

The Temp R-tron will display the humidity of the connected humidity sensors. It is possible to display each sensor separately. And display the operation of the relay and the fan speed.

Turn on power

1. Each time power is connected to the unit “4.0U” will appear on the display. This number is version number, and is unique for this program version.
2. The left display indicates the indoor temperature. The center display shows the outdoor temperature. And the right display shows the indoor humidity.

CHANGE OF DISPLAY

Push on  button. For select the display.





- SPF* This is a reading of the current fan speed.
- t1* This is a reading of the current indoor temperature 1.
- t2* This is a reading of the current indoor temperature 2.
- t3* This is a reading of the current outdoor temperature 3.
- t4* This is a reading of the current indoor temperature 4.
- Hu1* This is a reading of the current indoor humidity.
- AL1* Notification error (If no errors. Do not show this message.)
- *t1* Error from temperature sensor 1 alarm
 - *t2* Error from temperature sensor 2 alarm
 - *t3* Error from temperature sensor 3 alarm
 - *t4* Error from temperature sensor 4 alarm
 - *dte* Error of greater than or equal to the temperature 1 and 2 specified.
 - *HAL* Error of greater than or equal to the temperature specified.
 - *LAL* Error of less than or equal to the temperature specified.
 - *HHu* Error of greater than or equal to the humidity specified.
 - *tHS* Error of greater than or equal to the time heat stress index specified.
 - *AHS* Error of greater than or equal to the amount heat stress index specified.
 - *CO2* Error of greater than or equal to the CO₂ specified.

Push On  button. For select the display.

- F* Transfer current indoor temperature and outdoor temperature from Centigrade to Fahrenheit.

CHANGE OF SET POINT

It is possible to change each set point.

1. Press “Select”  button. For select the main functions.
 2. Press “” or “” button to select the sub functions.
 - 3 Press “Program” button. The lamp program will turn on.
 4. Press “” or “” button. Enter the desired value. The new data will appear on the display.
 5. Check the display to see if the desired value is correct. If correct, press the “Program” button to exit.
- The lamp program will off. The new desired value has been stored into the unit’s memory.

SET POINTS

Functions

1. Temperature for Fan ON/OFF

1.1 **F01 Set ON**

Enter here the temperature at fan1 turn on.

1.2 **F01 Set OFF**

Enter here the temperature at fan1 turn off.

1.3 **F02 Set ON**

Enter here the temperature at fan2 turn on.

1.4 **F02 Set OFF**

Enter here the temperature at fan2 turn off.

1.5 **F03 Set ON**

Enter here the temperature at fan3 turn on.

1.6 **F03 Set OFF**

Enter here the temperature at fan3 turn off.

1.7 **F04 Set ON**

Enter here the temperature at fan4 turn on.

1.8 **F04 Set OFF**

Enter here the temperature at fan4 turn off.

1.9 **F05 Set ON**

Enter here the temperature at fan5 turn on.

1.10 **F05 Set OFF**

Enter here the temperature at fan5 turn off.

1.11 **F06 Set ON**

Enter here the temperature at fan6 turn on.

1.12 **F06 Set OFF**

Enter here the temperature at fan6 turn off.

1.13 **F07 Set ON**

Enter here the temperature at fan7 turn on.

1.14 **F07 Set OFF**

Enter here the temperature at fan7 turn off.

1.15 **F08 Set ON**

Enter here the temperature at fan8 turn on.

1.16 **F08 Set OFF**

Enter here the temperature at fan8 turn off.

1.17 **F09 Set ON**

Enter here the temperature at fan9 turn on.

1.18 **F09 Set OFF**

Enter here the temperature at fan9 turn off.

1.19 **F 10 Set ON**

Enter here the temperature at fan10 turn on.

1.20 **F 10 Set OFF**

Enter here the temperature at fan10 turn off.

1.21 **F 11 Set ON**

Enter here the temperature at fan11 turn on.

1.22 **F 11 Set OFF**

Enter here the temperature at fan11 turn off.

1.23 **F 12 Set ON**

Enter here the temperature at fan12 turn on.

1.24 **F 12 Set OFF**

Enter here the temperature at fan12 turn off.

1.25 **F21 Set ON**

Enter here the time period in minutes and seconds (x10) that the fan1 will run once the house temperature has below the fan1 temperature (Function “F01”). The fan1 will run in an on-off cycle.

1.26 **F21 Set OFF**

Enter here the time period in minutes and seconds (x10) that the fan1 will be off during the fan1 cycle.

Note: Enter “0.0” to disable this function.

1.27 **F22 Set ON**

Enter here the time period in minutes and seconds (x10) that the fan2 will run once the house temperature below the fan2 temperature (Function “F02”). The fan2 will run in an on-off cycle.

1.28 **F22 Set OFF**

Enter here the time period in minutes and seconds (x10) that the fan2 will be off during the fan2 cycle.

Note: Enter “0.0” to disable this function.

1.29 **F23 Set ON**

Enter here the time period in minutes and seconds (x10) that the fan3 will run once the house temperature below the fan3 temperature (Function “F03”). The fan3 will run in an on-off cycle.

1.30 **F23 Set OFF**

Enter here the time period in minutes and seconds (x10) that the fan3 will be off during the fan3 cycle.

Note: Enter “0.0” to disable this function.

1.31 **F24 Set ON**

Enter here the time period in minutes and seconds (x10) that the fan4 will run once the house temperature below the fan4 temperature (Function “F04”). The fan4 will run in an on-off cycle.

1.32 **F24 Set OFF**

Enter here the time period in minutes and seconds (x10) that the fan4 will be off during the fan4 cycle.

Note: Enter “0.0” to disable this function.

1.33 **F25 Set ON**

Enter here the time period in minutes and seconds (x10) that the fan5 will run once the house temperature below the fan5 temperature (Function “F05”). The fan5 will run in an on-off cycle.

1.34 **F25 Set OFF**

Enter here the time period in minutes and seconds (x10) that the fan5 will be off during the fan5 cycle.

Note: Enter “0.0” to disable this function.

1.35 **F26 Set ON**

Enter here the time period in minutes and seconds (x10) that the fan6 will run once the house temperature below the fan6 temperature (Function “F06”). The fan6 will run in an on-off cycle.

1.36 **F26 Set OFF**

Enter here the time period in minutes and seconds (x10) that the fan6 will be off during the fan6 cycle.

Note: Enter “0.0” to disable this function.

1.37 **F27 Set ON**

Enter here the time period in minutes and seconds (x10) that the fan7 will run once the house temperature below the fan7 temperature (Function “F07”). The fan7 will run in an on-off cycle.

1.38 **F27 Set OFF**

Enter here the time period in minutes and seconds (x10) that the fan7 will be off during the fan7 cycle.

Note: Enter “0.0” to disable this function.

1.39 **F28 Set ON**

Enter here the time period in minutes and seconds (x10) that the fan8 will run once the house temperature below the fan8 temperature (Function “F08”). The fan8 will run in an on-off cycle.

1.40 **F28 Set OFF**

Enter here the time period in minutes and seconds (x10) that the fan8 will be off during the fan8 cycle.

Note: Enter “0.0” to disable this function.

1.41 **F29 Set ON**

Enter here the time period in minutes and seconds (x10) that the fan9 will run once the house temperature below the fan9 temperature (Function “F09”). The fan9 will run in an on-off cycle.

1.42 **F29 Set OFF**

Enter here the time period in minutes and seconds (x10) that the fan9 will be off during the fan9 cycle.

Note: Enter “0.0” to disable this function.

1.43 **F30 Set ON**

Enter here the time period in minutes and seconds (x10) that the fan10 will run once the house temperature below the fan10 temperature (Function “F10”). The fan10 will run in an on-off cycle.

1.44 **F30 Set OFF**

Enter here the time period in minutes and seconds (x10) that the fan10 will be off during the fan10 cycle.

Note: Enter "0.0" to disable this function.

1.45 **F31 Set ON**

Enter here the time period in minutes and seconds (x10) that the fan11 will run once the house temperature below the fan11 temperature (Function "**F 1 1**"). The fan11 will run in an on-off cycle.

1.46 **F31 Set OFF**

Enter here the time period in minutes and seconds (x10) that the fan11 will be off during the fan11 cycle.

Note: Enter "0.0" to disable this function.

1.47 **F32 Set ON**

Enter here the time period in minutes and seconds (x10) that the fan12 will run once the house temperature below the fan12 temperature (Function "**F 1 2**"). The fan12 will run in an on-off cycle.

1.48 **F32 Set OFF**

Enter here the time period in minutes and seconds (x10) that the fan12 will be off during the fan12 cycle.

Note: Enter "0.0" to disable this function.

Example:

F0 1 Set ON = 21.0°C

F0 1 Set OFF = 20.0°C

F2 1 Set ON = 5.0

F2 1 Set OFF = 10.0

As long as the indoor temperature is below 20.0°C. The fan1 will be turn on 5 minutes and turn off 10 minutes. When the temperature reaches 21.0°C. The fan1 will be turn on continued.

1.49 **t_L**

Enter here the minimum temperature setting to control the fan speed minimum.

1.50 **t_M**

Enter here the medium temperature setting to control the fan speed minimum.

1.51 **t_H**

Enter here the maximum temperature setting to control the fan speed maximum.

1.52 **SPF Lo**

Enter here the minimum speed set in percentage that the variable speed fan will run.

1.53 **SPF Med**

Enter here the medium speed set in percentage that the variable speed fan will run.

1.54 **SPF H_i**

Enter here the maximum speed set in percentage that the variable speed fan will run.

Example:

SPF L₀ = 10 %
 SPF iEd = 50 %
 SPF H_i = 100 %
 t_L = 21.0°C
 t_i = 25.0°C
 t_H = 30.0°C

As long as the indoor temperature is below 23.0°C the variable speed fan will be running at 30%. When the temperature reaches 23.0°C the variable speed fan will start to increase in speed. By the time the house temperature has reached 30.0°C variable speed fan will be running at 100%.

2. Temperature for Cooling / Heater ON/OFF

2.1 **H₀ I Set ON**

Enter here the temperature at heater turn on.

2.2 **H₀ I Set OFF**

Enter here the temperature at heater turn off.

Example:

H₀ I Set ON = 29.0°C
 H₀ I Set OFF = 30.0°C

When the temperature is lower than or equal to 29.0°C, heater will turn on. And temperature greater than or equal to 30.0°C, heater will turn off.

Cooling Pump

When the indoor temperature is equal or over requested temperature for cooling system, a line (see line 1~4 at table page14) can be active only when all the following conditions are fulfilled: time and temperature.

Cooling Table

Period (Pr ₋)	From Time (hh.m) ("on Pr ₋ ")	To Time ("of Pr ₋ ")	Outdoor Temperature ("t ₃ Pr ₋ ")	On (mm.s) ("onP Pr ₋ ")	Off (mm.s) ("ofP Pr ₋ ")
1	0:00	24:00	27.0	2:00	10:00
2	0:00	24:00	29.0	2:00	5:00
3	0:00	24:00	30.0	2:00	2:00
4	12:30	16:00	32.5	2:00	0:00

Example: When the outdoor temperature is below 27°C, under the assumption that the range of both time, the cooling system will not operate when the outdoor temperature reaches or rises over 27°C. The cooling system operates according to the first line when the temperature rises over 29.0°C, the cooling system will operate according to line 2 and so on.

Cooling Pump

2.3 **CO1** Set ON

Enter here the temperature at cooling pump1 turn on.

2.4 **CO1** Set OFF

Enter here the temperature at cooling pump1 turn off.

2.5 **CO2** Set ON

Enter here the temperature at cooling pump2 turn on.

2.6 **CO2** Set OFF

Enter here the temperature at cooling pump2 turn off.

2.7 **on Pr1** From Time Period 1

Enter here the cooling system on time for cooling table period 1. Use real time mode.

2.8 **off Pr1** To Time Period 1

Enter here the cooling system off time for cooling table period 1. Use real time mode.

2.9 **t3 Pr1** Outdoor Temperature Period 1

Enter here an outdoor temperature for cooling table period 1.

2.10 **onP Pr1** Time On Pump Period 1

Enter here the time period in minutes and seconds that the cooling system will run in an on-off cycle for cooling table period 1.

2.11 **offP Pr1** Time Off Pump Period 1

Enter here the time period in minutes and seconds that the cooling system will be off during the cooling system cycle for cooling table period 1.

2.12 **on Pr2** From Time Period 2

Enter here the cooling system on time for cooling table period 2. Use a real time mode.

2.13 **off Pr2** To Time Period 2

Enter here the cooling system off time for cooling table period 2. Use real time mode.

2.14 **t3 Pr2** Outdoor Temperature Period 2

Enter here an outdoor temperature for cooling table period 2.

2.15 **onP Pr2** Time On Pump Period 2

Enter here the time period in minutes and seconds that the cooling system will run in an on-off cycle for cooling table period 2.

2.16 **offP Pr2** Time Off Pump Period 2

Enter here the time period in minutes and seconds that the cooling system will be off during the cooling system cycle for cooling table period 2.

2.17 **on Pr3** From Time Period 3

Enter here the cooling system on time for cooling table period 3. Use a real time mode.

2.18 **off Pr3** To Time Period 3

Enter here the cooling system off time for cooling table period 3. Use real time mode.

2.19 **t3 Pr3** Outdoor Temperature Period 3

Enter here an outdoor temperature for cooling table period 3.

2.20 **onP Pr3** Time On Pump Period 3

Enter here the time period in minutes and seconds that the cooling system will run in an on-off cycle for cooling table period 3.

2.21 **offP Pr3** Time Off Pump Period 3

Enter here the time period in minutes and seconds that the cooling system will be off during the cooling system cycle for cooling table period 3.

2.22 **on Pr4** From Time Period 4

Enter here the cooling system on time for cooling table period 4. Use a real time mode.

2.23 **off Pr4** To Time Period 4

Enter here the cooling system off time for cooling table period 4. Use real time mode.

2.24 **t3 Pr4** Outdoor Temperature Period 4

Enter here an outdoor temperature for cooling table period 4.

2.25 **onP Pr4** Time On Pump Period 4

Enter here the time period in minutes and seconds that the cooling system will run in an on-off cycle for cooling table period 4.

2.26 **offP Pr4** Time Off Pump Period 4

Enter here the time period in minutes and seconds that the cooling system will be off during the cooling system cycle for cooling table period 4.

2.27 **on Pr5** From Time Period 5

Enter here the cooling system on time for cooling table period 5. Use a real time mode.

2.28 **off Pr5** To Time Period 5

Enter here the cooling system off time for cooling table period 5. Use real time mode.

2.29 **t3 Pr5** Outdoor Temperature Period 5

Enter here an outdoor temperature for cooling table period 5.

2.30 **onP Pr5** Time On Pump Period 5

Enter here the time period in minutes and seconds that the cooling system will run in an on-off cycle for period 5.

2.31 **oFP Pr5** Time Off Pump Period 5

Enter here the time period in minutes and seconds that the cooling system will be off during the cooling system cycle for cooling table period 5.

3. Humidity for Cooling OFF

3.1 **H_U**

Enter here the humidity at pump turned off. The humidity at the turn on pump is calculated from the value of

H_U minus the value of HH. As set **H_U**= 80.0% and **HH**=2.0%, pump will turn off at 80.0% and will turn on again when humidity is less than or equal to 78.0%. (Factory - set value **HH** = 2.0%. Users can edit it.)

3.2 **onP HH_U**

Enter here the time period in minutes and seconds (x10) that the cooling pump system will run once the indoor temperature has reached the required temperature for cooling pump and indoor humidity rises above required humidity. The cooling pump will run in an on-off cycle.

3.3 **oFP HH_U**

Enter here the time period in minute and seconds (x10) that the cooling pump will be off during high humidity cycle.

Note: Enter "0.0" to disable this function

3.4 **FA_n HH_U**

Enter here number X to turn on fan X. The humidity at the turn on fan from the value of **H_U**.

Note: Enter "0" to disable this function

3.5 **onF HH_U**

Enter here the time period in minutes and seconds (x10) that the fan will run once the humidity reaches the **H_U** value. The fan will run in an on-off cycle.

3.6 **oFF HH_U**

Enter here the time period in minutes and seconds (x10) that the fan will be off during the fan cycle.

Note: Enter "0.0" to disable this function.

3.7 **SPF HH_U**

Enter here the speed set in percentage that the variable speed fan will run. The humidity to turn on fan from the value of **H_U**.

Note: Enter "0" to disable this function

3.8 **onS HH_U**

Enter here the time period in minutes and seconds (x10) that the fan will run once the humidity reaches the **H_U** value. The fan will run in an on-off cycle.

3.9 **oFS HH_U**

Enter here the time period in minutes and seconds (x10) that the fan will be off during the fan cycle.

Note: Enter "0.0" to disable this function.

4. Time Update

4.1 Hr

This is a reading of the hour setting. It is possible here to adjust the hour reading.

4.2 ĩ ĩ

This is a reading of the minute setting. It is possible here to adjust the minute reading.

4.3 dAY

This is a reading of the day setting. It is possible here to adjust the day reading.

4.4 dd

This is a reading of the date setting. It is possible here to adjust the date reading.

4.5 ĩ ĩ ĩ

This is a reading of the month setting. It is possible here to adjust the month reading.

4.7 YY

This is a reading of the year setting. It is possible here to adjust the year reading.

5. Set Times for Light ON/OFF and Feed ON/OFF

Light On /Off

5.1 L 1 Set ON

Enter here the time period 1 at light turn on.

5.2 L 1 Set OFF

Enter here the time period 1 at light turn off.

5.3 L 2 Set ON

Enter here the time period 2 at light turn on.

5.4 L 2 Set OFF

Enter here the time period 2 at light turn off.

5.5 L 3 Set ON

Enter here the time period 3 at light turn on.

5.6 L 3 Set OFF

Enter here the time period 3 at light turn off.

5.7 L 4 Set ON

Enter here the time period 4 at light turn on.

5.8 L 4 Set OFF

Enter here the time period 4 at light turn off.

5.9 L 5 Set ON

Enter here the time period 5 at light turn on.

5.10 L 5 Set OFF

Enter here the time period 5 at light turn off.

Feed On/Off

For Feed On/Off control. It is possible to enable function before using. Please see parameter setup 8.13 **CP2**

To enable select **Fd** and Enter “ Program “ for confirm. For relay contact use terminal CP2 and CMP2

5.11 **Fd1** Set ON

Enter here the Feed time period 1 at CP2 turn on.

5.12 **Fd1** Set OFF

Enter here the Feed time period 1 at CP2 turn off.

5.13 **Fd2** Set ON

Enter here the Feed time period 2 at CP2 turn on.

5.14 **Fd2** Set OFF

Enter here the Feed time period 3 at CP2 turn off.

5.15 **Fd3** Set ON

Enter here the Feed time period 3 at CP2 turn on.

5.16 **Fd3** Set OFF

Enter here the Feed time period 3 at CP2 turn off.

5.15 **Fd4** Set ON

Enter here the Feed time period 4 at CP2 turn on.

5.16 **Fd4** Set OFF

Enter here the Feed time period 4 at CP2 turn off.

5.17 **Fd5** Set ON

Enter here the Feed time period 5 at CP2 turn on.

5.18 **Fd5** Set OFF

Enter here the Feed time period 5 at CP2 turn off.

6. Alarm

6.1 **H AL**

Enter here the maximum temperature required notification. In case of the controller will activate the alarm relay and high temperature alarm status will activate.

6.2 **Lo AL**

Enter here the minimum temperature required notification. In case of the controller will activate the alarm relay and low temperature alarm status will activate.

6.3 **HHU AL**

Enter here the maximum humidity required notification. In case of the controller will activate the alarm relay and high humidity alarm status will activate.

6.4 **EE1 AL** Indoor Temperature Sensor 1 Alarm

It is possible to enable temperature sensor 1 alarm

To disable an alarm enter the corresponding off.

To enable an alarm enter the corresponding on.

Note: If an alarm is disabled then the alarm relay will not be activated when there is a problem.

6.5 **EE2 AL** Indoor Temperature Sensor 2 Alarm

It is possible to enable temperature sensor 2 alarm

To disable an alarm enter the corresponding off.

To enable an alarm enter the corresponding on.

Note: If an alarm is disabled then the alarm relay will not be activated when there is a problem.

6.6 **EE3 AL** Indoor Temperature Sensor 3 Alarm

It is possible to enable temperature sensor 3 alarm

To disable an alarm enter the corresponding off.

To enable an alarm enter the corresponding on.

Note: If an alarm is disabled then the alarm relay will not be activated when there is a problem.

6.7 **EE4 AL** Indoor Temperature Sensor 4 Alarm

It is possible to enable temperature sensor 4 alarm

To disable an alarm enter the corresponding off.

To enable an alarm enter the corresponding on.

Note: If an alarm is disabled then the alarm relay will not be activated when there is a problem.

6.8 **dTE AL**

Enter here the different temperature required notification. In case of the controller will activate the alarm relay and different temperature alarm status will activate.

6.9 **HS AL**

Enter here the number of the heat stress index. When the indoor temperature plus indoor humidity in the house is above this value, the heat stress status will be activated.

6.10 **AHS AL**

Enter here the number of amount time in the heat stress. When amount time in the heat stress is over this value, the controller will activate the alarm relay and amount time heat stress alarm status will activate.

6.11 **EHA AL**

Enter here the time in minutes of amount time in the heat stress.

6.12 **EHS AL**

Enter here the time in minutes of time in the heat stress. When time period in the heat stress is above this value, the controller will activate the alarm relay and the time heat stress alarm status will activate.

6.13 **EAL** Set *On*

Enter here the time period in seconds that the alarm system will run. The alarm system will activate.

6.14 **EA**L Set *off*

Enter here the time period in seconds that the alarm system will be off.

7. Max./Min. Values

7.1 **-E-** Total Water Consumption

This is a reading of the total water consumption in the house.

7.2 **HE** | Indoor High Temperature in today

This is a reading of Indoor high temperature in today. Press  for time recording.

7.3 **LE** | Low indoor Temperature in today

This is a reading of Indoor low temperature in today. Press  for time recording.

7.4 **he** | High outdoor Temperature in today

This is a reading of Outdoor high temperature in today. Press  for time recording.

7.5 **le** | Low outdoor Temperature in today

This is a reading of Outdoor low temperature in today. Press  for time recording.

7.6 **HH** | High Humidity in today

This is a reading of Indoor high humidity in today. Press  for time recording.

7.7 **LH** | Low Humidity in today

This is a reading of Indoor low humidity in today. Press  for time recording.

7.8 **EH** | Time Heat stress in today

This is a reading of total longest time period (minute) when there is a heat stress index in today.

Press  for time recording.

7.9 **HS** | Heat stress in today

This is a reading of highest value of the heat stress index in today. Press  for time recording.

7.10 **AH** | Amount Heat stress in today

This is a reading of amount of events when there are the heat stress indexes in today.

Press  for time recording.

7.11 **-C I** Water Consumption in today

This is a reading of water consumption in today.

7.12 **Co I** High CO₂ in today

This is a reading of the high indoor CO₂ in today. Press  for time recording.

7.13 **Ht2** to **Co2** This is data recoding for yesterday.

7.14 **Ht3** to **Co3** This is data recoding for 2 Days ago.

8. Parameter Setup

8.1 **t 1** (°C) Indoor Temperature No. 1

This is a reading of the current indoor temperature 1. It is possible here to adjust the temperature reading.

8.2 **t 2** (°C) Indoor Temperature No. 2

This is a reading of the current indoor temperature 2. It is possible here to adjust the temperature reading.

8.3 **t 3** (°C) Outdoor Temperature

This is a reading of the current outdoor temperature. It is possible here to adjust the temperature reading.

8.4 **t 4** (°C) Indoor Temperature No. 3

This is a reading of the current indoor temperature 3. It is possible here to adjust the temperature reading.

8.5 **Hu** (%RH) Indoor Humidity

This is a reading of the current indoor humidity. It is possible here to adjust the humidity reading.

8.6 **Hn** House Number

It is possible to connect the unit to a PC computer with the help of the “TEMPVIEW” software package. It is possible to manage up 99 units. Each controller needs a house number.

8.7 **id** Formula Number

This is the formula number of the controller.

8.8 **tSn** Indoor Temperature Sensor Control

It is possible to use partial or all indoor temperature sensors for control.

To use temperature sensor 1 enter the corresponding **t 1**.

To use temperature sensor 2 enter the corresponding **t 2**.

To use temperature sensor 4 enter the corresponding **t 4**.

To use temperature sensor 1 and 2 enter the corresponding **1-2**.

To use all temperature sensor enter the corresponding **ALL**.

8.9 **hTS** Indoor Temperature Sensor Control Heater

It is possible to use indoor temperature sensor for control.

To use temperature sensor 1 enter the corresponding **t 1**.

To use temperature sensor 2 enter the corresponding **t 2**.

To use temperature sensor 4 enter the corresponding **t 4**.

To use temperature sensor 1 and 2 enter the corresponding **1_2**.

To use all temperature sensor enter the corresponding **ALL**.

8.10 **HSn** Indoor Humidity Sensor Control

It is possible to use indoor humidity sensor for control.

To use humidity sensor enter the corresponding **on**.

To not use humidity sensor enter the corresponding **OFF**.

8.11 **dP** Select Display Brooding Temperature

It is possible to select display brooding temperature for show. Press  LED is light for select parameter.

To show temperature control heater enter the corresponding **hTS**. Press  for confirm parameter.

To show outdoor temperature enter the corresponding **t3**. Press  for confirm parameter.

To show CO₂ enter the corresponding **CO2**. Press  for confirm parameter.

To show speed variable fan enter the corresponding **FSP**. Press  for confirm parameter.

8.12 **F 12** Select Use Relay Fan 12

It is possible to use relay Fan12 for other functions. Press  LED is light for select parameter.

To use for Fan12 enter the corresponding **FAn**. Press  for confirm parameter.

To use for Feed enter the corresponding **Fd**. Press  for confirm parameter.

To use for heater enter the corresponding **ht**. Press  for confirm parameter.

8.13 **CP2** Select Use Relay CP2

It is possible to use relay CP2 for other functions. Press  LED is light for select parameter.

To use for Cooling Pump2 enter the corresponding **CP2**. Press  for confirm parameter.

To use for heater enter the corresponding **ht**. Press  for confirm parameter.

To use for Feeding enter the corresponding **Fd**. Press  for confirm parameter.

8.14 **HH** Humidity Hysteresis

Enter here the number of percentage below the requested humidity for cooling system (function "**HL**") that cooling system will be turn on.

8.15 **dLY** Delay Turn on System

Enter here the time period in seconds that the controller will be delay turn on relay in case of power on.

8.16 **tdL** Time Event Data Logger

Enter here the time interval in minutes (5, 15, 30, 60, 120 minute) that the data logger will get record.

8.17 **C_P** Change Password

Enter here a change password.

8.18 **rSt**

This is function for reset controller. To be used by technicians.

- 1 = Load User Parameter
- 2 = Clear Adjust Sensor
- 3 = Clear Data Logger
- 4 = Clear Max, Min Value
- 5 = Load Factory Parameter
- 8 = Save User Parameter

8.19 **trL**

This is function for test relay. To be used by technicians.

8.20 **tSF**

This is function for test variable speed fan. To be used by technicians.

8.21 **tdP**

This is function for test 7 segments. To be used by technicians.

8.22 **tdI**

This is function for test digital input. To be used by technicians.
